

FX2 SQUARE TRIM SUBMITTAL : DIMENSIONS

TRIM & DOOR SERIES #		Tub I.D.			Frame O.D.		Wall Opening		
Model	Trim Style	A	B	C	E	F	W	H	D
8116	1-1/2" Square	9	18	5 1/2	12 3/8	21 3/8	11 5/16	20 5/16	5 3/16
1816	1-1/2" Square	10 1/2	24	5 1/2	13 7/8	27 3/8	12 13/16	26 5/16	5 3/16
1016	1-1/2" Square	10 1/2	24	6	13 7/8	27 3/8	12 13/16	26 5/16	5 11/16
2016	1-1/2" Square	12	27	7 3/4	15 3/8	30 3/8	14 5/16	29 5/16	7 11/16
3016	1-1/2" Square	16	32	7 3/4	19 3/8	35 3/8	18 5/16	34 5/16	7 11/16
4016	1-1/2" Square	20	27	7 3/4	23 3/8	30 3/8	22 5/16	29 5/16	7 11/16

FX2 ROLLED TRIM SUBMITTAL : DIMENSIONS

TRIM & DOOR SERIES #		Tub I.D.			Frame O.D.		Wall Opening		
Model	Trim Style	A	B	C	E	F	W	H	D
8117	2-1/2" Rolled	9	18	5 1/2	12 3/8	21 3/8	11 5/16	20 5/16	4
2017	2-1/2" Rolled	12	27	7 3/4	15 3/8	30 3/8	14 5/16	29 5/16	6 7/16
3017	2-1/2" Rolled	16	32	7 3/4	19 3/8	35 3/8	18 5/16	34 5/16	5 3/8
4017	2-1/2" Rolled	20	27	7 3/4	23 3/8	30 3/8	22 5/16	29 5/16	6 7/16
1817	3" Rolled	10 1/2	24	5 1/2	13 7/8	27 3/8	12 13/16	26 5/16	3 5/8
1017	3" Rolled	10 1/2	24	6	13 7/8	27 3/8	12 13/16	26 5/16	4
8118	4-1/2" Rolled	9	18	5 1/2	12 3/8	21 3/8	11 5/16	20 5/16	2 3/6
1818	4-1/2" Rolled	10 1/2	24	5 1/2	13 7/8	27 3/8	12 13/16	26 5/16	2 3/16
1018	4-1/2" Rolled	10 1/2	24	6	13 7/8	27 3/8	12 13/16	26 5/16	2 11/16
2018	4-1/2" Rolled	12	27	7 3/4	15 3/8	30 3/8	14 5/16	29 5/16	4 7/16
3018	4-1/2" Rolled	16	32	7 3/4	19 3/8	35 3/8	18 5/16	34 5/16	4 7/16
4018	4-1/2" Rolled	20	27	7 3/4	23 3/8	30 3/8	22 5/16	29 5/16	4 7/16

FX2 ROLLED-FLUSH PULL TRIM SUBMITTAL : DIMENSIONS

TRIM & DOOR SERIES #		Tub I.D.			Frame O.D.		Wall Opening		
Model	Trim Style	A	B	C	E	F	W	H	D
1812	Rolled-Flush Pull	10 1/2	24	5 1/2	13 7/8	27 3/8	12 13/16	26 5/16	2 7/8
1012	Rolled-Flush Pull	10 1/2	24	6	13 7/8	27 3/8	12 13/16	26 5/16	3 3/8
2012	Rolled-Flush Pull	12	27	7 3/4	15 3/8	30 3/8	14 5/16	29 5/16	5 1/8
3012	Rolled-Flush Pull	16	32	7 3/4	19 3/8	35 3/8	18 5/16	34 5/16	5 1/8
4012	Rolled-Flush Pull	20	27	7 3/4	23 3/8	30 3/8	22 5/16	29 5/16	4 7/16

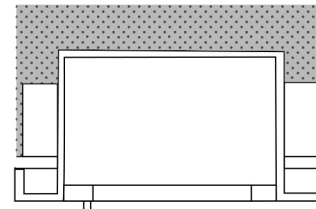
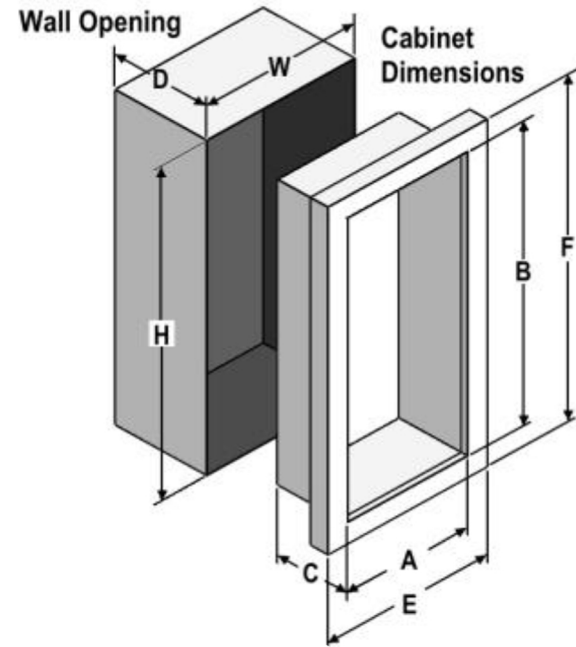

1-1/2" Square Trim

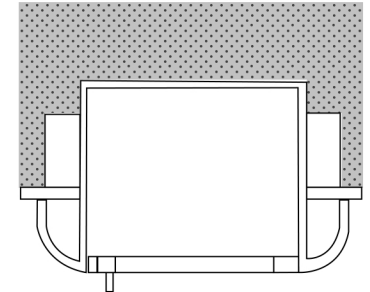

2-1/2, 3" Rolled Edge

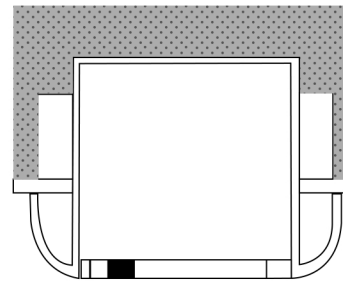

4" Rolled-Flush Pull

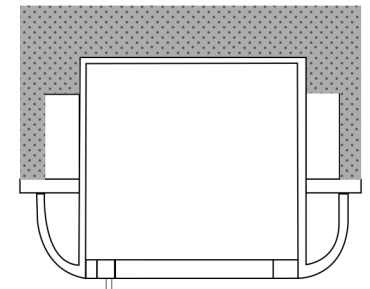

4.5" Rolled Edge